

MAXON®

SPECIFICATIONS



CONVENTIONAL

MODELS: TG-150, TG-20

- **General Purpose Freight**
- **Tail Gate Style**
- **Standard Ride**

A descendant of the original liftgate designs, MAXON's new TG Series is a work horse for general freight handling and ground level loading/unloading.

Recommended for stake or van body applications where dock loading is not required. New folding mechanism allows easy installation on swing door bodies.

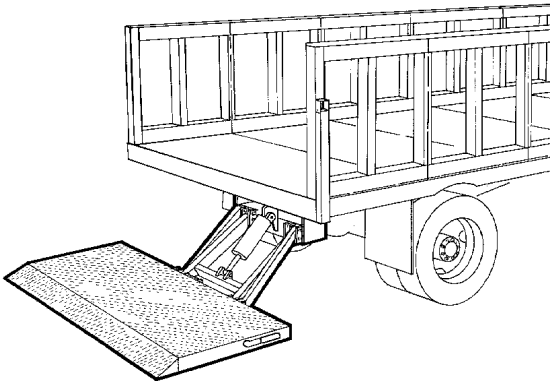
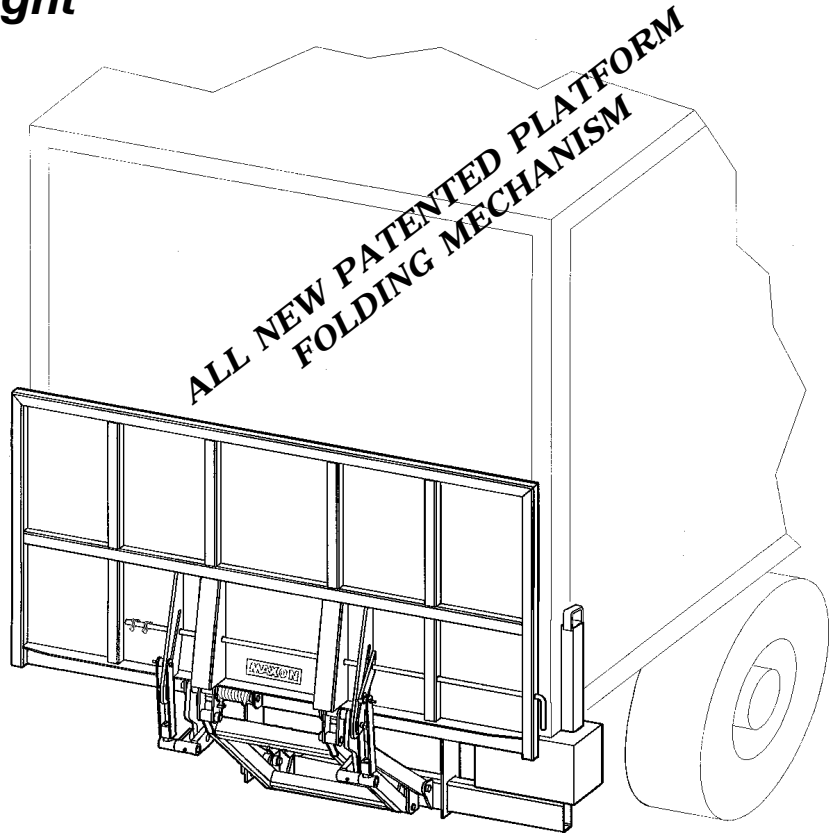

The Low Maintenance Series takes liftgate technology to new levels by reducing maintenance requirements and increasing product life.

MODEL	CAPACITY	PLATFORM SIZE	RAMP OPTIONS
TG-150	1500 LBS.	36" X 86" (90" Body Width) 36" X 92" (96" Body Width)	
TG-20	2000 LBS.	36" x 80" (84" Body Width) 42" x 80" (84" Body Width) 48" x 80" (84" Body Width) 36" x 86" (90" Body Width) 42" x 86" (90" Body Width) 48" x 68" (90" Body Width) 36" x 92" (96" Body Width) 42" x 92" (96" Body Width) 48" x 92" (96" Body Width)	6" FIXED 12" FIXED 12" FIXED (SINGLE CART STOP) 12" FIXED (DUAL CART STOP)

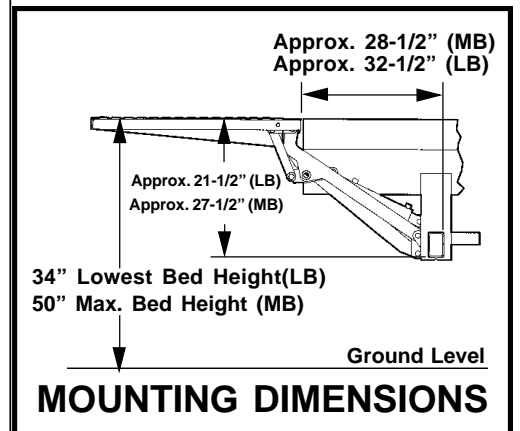

◆ New, Lower Bed Height Capability

With the number of smaller trucks increasing, the TG Series is designed to meet the needs of this market with a lower minimum loaded bed height requirement of 34".

◆ Pump and Motor Enclosure

A weather tight, powder coated pump box is standard. It has a fully integrated box/tank design with an external sight glass for convenient oil level inspection. The new Vertical design allows ease of service to any pump component. It also comes standard with Thermal Overload protection.

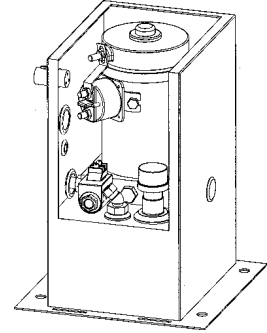

◆ Lower Maintenance

All pins on the TG Series are plated and supported by self-lubricated bearings. There are no grease fittings on the liftgate because the TG Series *never* needs grease. The TG Series has double the previous bearing surface for longer bearing and pin life.

◆ Exclusive MAXON 4 Step Coating Process

MAXON has implemented this exclusive 4 step Coating Process to obtain a finish designed to give the TG Series corrosion resistance for years.

◆ All New Patented Platform Folding Mechanism

The TG Series design uses MAXON's new patented folding mechanism to move the platform smoothly from the horizontal *load carrying* position, to the vertical *stowed* position. The new design is fully integrated into the liftgate's structure and requires no body mounted cams. Unnecessary valving and cylinders are also eliminated, reducing maintenance costs over the life of the liftgate.

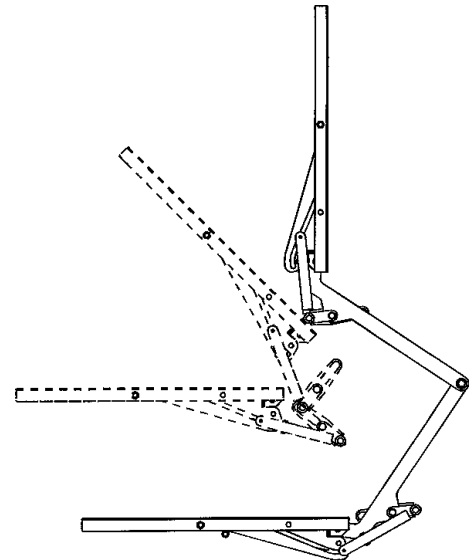

PATENT # 5,277,275

OPTIONS

- | | |
|--|---|
| <input type="checkbox"/> Hand Held Control | <input type="checkbox"/> Ramp Options |
| <input type="checkbox"/> Street Side Control | <input type="checkbox"/> 6" Fixed |
| <input type="checkbox"/> Power Down | <input type="checkbox"/> 12" Fixed |
| <input type="checkbox"/> Auxiliary Battery Kit | <input type="checkbox"/> 12" Fixed Single Cart Stop |
| <input type="checkbox"/> Truck | <input type="checkbox"/> 12" Fixed Dual Cart Stop |
| <input type="checkbox"/> Trailer | |

Distributed By:

M125-0902