



SPECIFICATIONS

Models: RCM-12, RCM-12AB, RCM-16, RCM-16AB

RCM Liftgates

Level Ride Platforms for Medium-Duty and Low Bed Applications with Optional Above-Bed Travel

Designed for delivery systems requiring Medium Duty lifting capacities. No other liftgate offers the high performance and low maintenance of the RCM. Popular applications include full size and narrow van bodies, cutaways, step vans, platform and stake bodies. Also available are the above bed travel, AB Models for dock delivery from vehicles with bed heights lower than dock height.

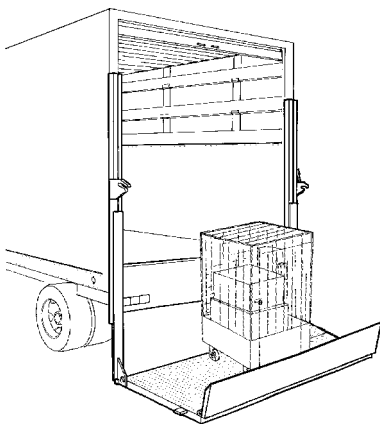

Optional 10" Aluminum Retention Ramp is ideal for handling wheeled carts. Self-lubricating hinges allow easy adjustment from stored, retention, and ramp positions; it also includes MAXON's patented automatic ramp latch for simplified operation.

Platform lowers below bed for dock loading or access to light parcels.

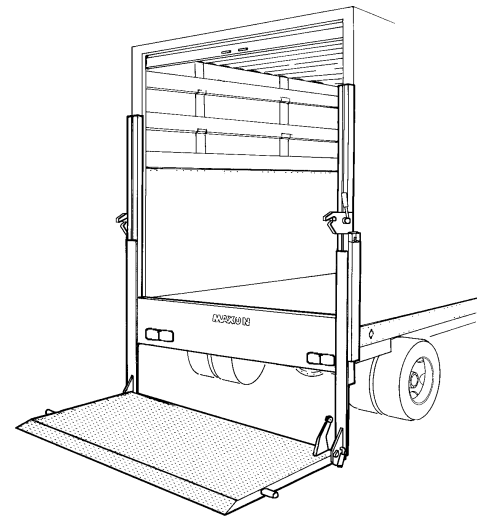
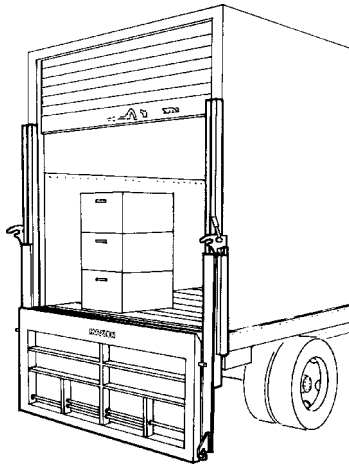

Level ride, Low Profile platforms are standard with 6" Fixed Ramp. All RCMs use forklift chain for strong long lasting performance.

MODEL	BODY WIDTH	PLATFORM AREA	RAMP	LIFT DIMENSIONS						
RCM-12 1250 lbs.	86"	30" x 80"	6" Fixed (Standard for all RCM Models)	<table border="1"> <thead> <tr> <th>Model</th> <th>Height</th> </tr> </thead> <tbody> <tr> <td>RCM-12 RCM-16</td> <td>30"-56"</td> </tr> <tr> <td>RCM-12AB RCM-16AB</td> <td>30"-52"</td> </tr> </tbody> </table>	Model	Height	RCM-12 RCM-16	30"-56"	RCM-12AB RCM-16AB	30"-52"
Model		Height								
RCM-12 RCM-16		30"-56"								
RCM-12AB RCM-16AB	30"-52"									
RCM-12AB 1250 lbs. (Above Bed Travel)	30" x 85"									
	30" x 90"									
RCM-16 1600 lbs.	90"	30" x 80"	10" Aluminum Retention Ramp (Optional on 36" Platforms)							
	96"	36" x 80"								
		30" x 85"								
RCM-16AB 1600 lbs. (Above Bed Travel)		36" x 85"								
		30" x 90"								
		36" x 90"								

SPECIFICATIONS

Models: RCM-12, RCM-12AB, RCM-16, RCM-16AB

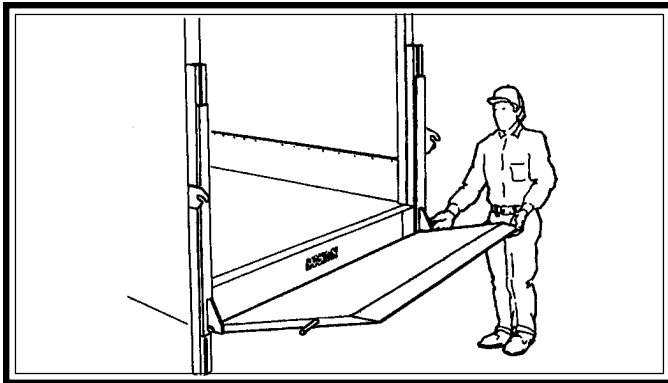

EASY CLOSING PLATFORM

Platform closing is assisted by powerful adjustable double torsion bars, designed to reduce the force required to close the platform to 15 Lbs. or less.

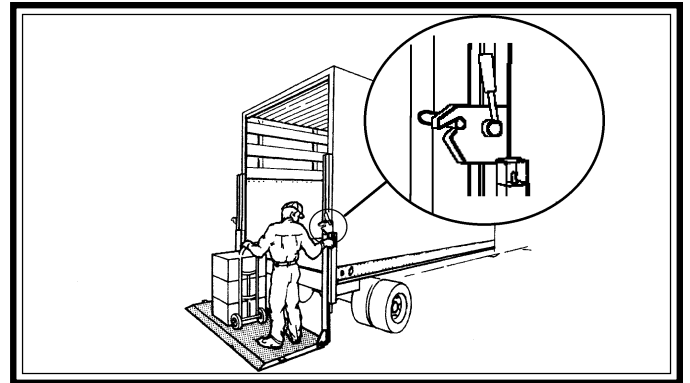

SIMPLE, AUTOMATIC CONTROLS

MAXON's Electric Switch Control Station is mounted on the curbside liftgate column making it easily accessible from the ground or while riding on the platform. The Automatic Safety Latch engages to keep platform in stowed position in the event of hydraulic failure. Requires no driver effort.

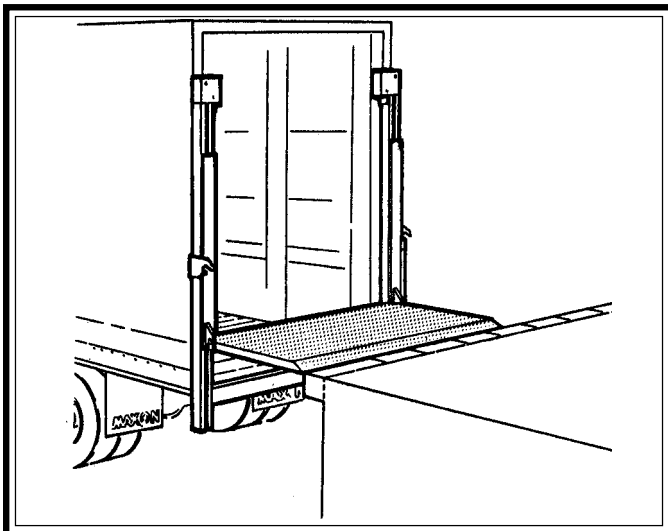

ABOVE BED PLATFORM TRAVEL FOR LOW BED APPLICATIONS

The RCM-AB models allow the platform to rise above bed height when installed on low bed vehicles. This provides access to docks up to 52" high

FORKLIFT TYPE LEAF CHAIN

The RCM uses forklift technology in it's use of leaf chain to lift our loads.

STANDARD EQUIPMENT

- Plastic Pump and Motor Enclosure
- Marine Style Electric Switch Controls
- Above Bed Travel (On "AB" Models)
- 4 Step Paint Process

OPTIONAL EQUIPMENT

- * Auxiliary Hand Pump
- * 150 AMP Circuit Breaker
(No Charge Option)
Hand Held Control
- * Preferred Options

Distributed By:

M101-0402

MAXON LIFT CORP. 11921 Slauson Ave., Santa Fe Springs, CA. 90670-2221
(800) 227-4116, FAX: (888) 771-7713 Internet: <http://www.maxonlift.com>