

The Mighty Max MM-1300 Model Liftgates

Designed for today's full-sized pickup and utility body trucks, the Mighty Max 1300 is built with high performance, low maintenance features.

- 1,300 lb. capacity
- Designed to fit full-sized domestic pickup beds and most popular utility bodies
- Choose from steel, aluminum, or grip strut platforms
- Ramp options increase loadable platform depth
- Direct lift with level ride platform
- Chrome plated cylinder rods
- Platform doubles as the vehicle's tailgate
- Equipped with maintenance-free, grease-free bearings
- Standard key switch protects against unauthorized use
- Oversized, fully enclosed pump and motor ensures increased life and reliability
- Curbside toggle switch is water-resistant and recessed to prevent damage from accidental impact



MIGHTY MAX

| Model Capacity | Platform Size | Total Weight | Bed Height | Vehicles |
|------------------------|---------------|--------------|--|---|
| MM-1300 (1300 Lbs.) | 30" x 49" | 406 Lbs. | Please Contact Customer Service | Standard Utility/ Classic Service Body |
| | 30" x 54" | 420 Lbs. | | Full Size Pickups |
| | 46" x 56"* | 458 Lbs. | | Full Size Pickups |

Optional Features

- 12" Flipover Section (increases loadable space by 40%)**
- Cab Power Cut-Off Switch
- Grip Strut Platform (Zinc Plated)
- Aluminum Platform
- Extra Bracket Kit
- Tire Stand for Grip Strut Platform

* Special Order Request

** Steel Platform Only

Distributed by:

Maxon Lift Corp.

11921 Slauson Ave., Santa Fe Springs, CA 90670

Tel: 562.464.0099 • 800.227.4116 • Fax: 888.771.7713

www.maxonlift.com

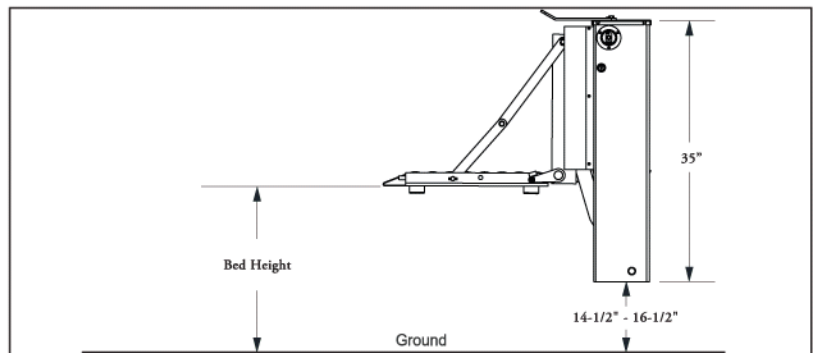

Lift Dimensions